

- RFID operation
- All metal housing
- Vertical body style
- Non-handed
- With knob or ADA compliant lever
- Brushed nickel finish
- Cam locking mechanism
- Visual & audible indicators
- Manage with electronic keys
- 3-5 year battery life
- Powered by 3 premium AA batteries
- Up to 5 year warranty



- Accommodates door thickness of 0.03"-1.13" (0.8 - 28.6 mm)
- Strike plate
- Compatible RFID standards:
 - ISO 14443A
 - ISO 14443B
 - ISO 15693



Advanced Security cam locks with levers operated with an Accessibility User Key are fully compliant with the Americans with Disabilities Act (ADA) guidelines set by the U.S. Access Board

Back View

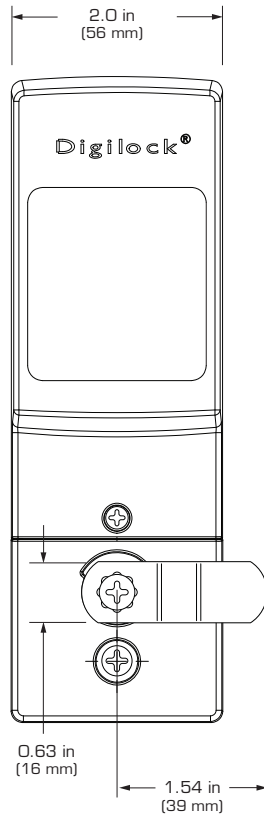

Side View

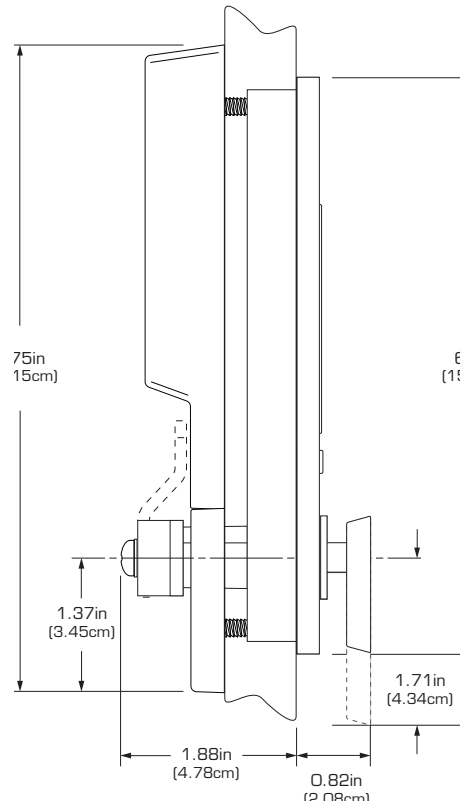

Front View

